

MEMPHIS LIGHT, GAS & WATER DIVISION

# FACILITY CONNECTION REQUIREMENTS

---

## ELECTRIC SYSTEM

**JANUARY 2023**  
**Revision 7.0**

TRANSMISSION AND OPERATIONAL PLANNING

# SIGNATURES

## FACILITY CONNECTION REQUIREMENTS

DocuSigned by:  
*Stacy Okai*  
PREPARED: B606DC660EE148D... DATE: 1/5/2023  
Stacy Okai  
Planning Engineer, Transmission and Operational Planning

DocuSigned by:  
*Bryant Williamson*  
APPROVED: A8FD43E7630843F... DATE: 1/5/2023  
Bryant Williamson, P.E.  
Supervisor, Transmission and Operational Planning

DocuSigned by:  
*Reggie Bowlin*  
APPROVED: C262142A4E6C47C... DATE: 1/5/2023  
Reggie Bowlin, P.E.  
Manager, Systems Operations

DocuSigned by:  
*Jon Mosteller*  
APPROVED: 30ED8A1E6E85485... DATE: 1/5/2023  
Jon Mosteller, P.E.  
Supervisor, Substation and Transmission Engineering

DocuSigned by:  
*W Ellis*  
APPROVED: D6EC0DC70285481... DATE: 1/5/2023  
Wayne Ellis, P.E.  
Manager, Electric Substation Engineering and Operations

DocuSigned by:  
*Nick Newman*  
APPROVED: 8822A1D37B394D1... DATE: 1/5/2023  
Nick Newman  
Vice President, Engineering and Operations

# REVISION HISTORY

## FACILITY CONNECTION REQUIREMENTS

Version	Author	Date	Description of Change(s)
0	Kristin Hensley	08-31-2010	Initial Release
1	Kristin Hensley	10-18-2011	Made extensive additions to specify throughout
2	Bryant Williamson	10-16-2012	Contact Information Updated
3	Bryant Williamson	10-16-2013	Post Audit Edits and Review
3.1	Randell Hyneman	10-16-2014	Annual Review
4	Randell Hyneman	05-28-2015	Update Sec 2.04/3.01 to Reflect New TPL-001-4 Contingency Standards
4.1	Randell Hyneman	05-28-2016	Minor Change – Removal of FAC-001 references due to standard update
4.2	Randell Hyneman	05-28-2017	Reviewed with no changes
4.3	Randell Hyneman	05-28-2018	Reviewed with no changes
5	Amber Isbell	01-25-2019	Updated technical specifications and impact requirements
5.1	Amber Isbell	1-22-2020	Reviewed with no changes
6	Randell Hyneman	1-20-2021	Annual Review: Checked Standards referenced Page 22 - Changed IRO-001-1 to IRO-001 Page 2 - Updated signature Page Page 3 - Changed Revision table layout
6.1	Randel Hyneman	1-19-2022	Annual Review – No Changes
7.0	Stacy Okai	1-05-2023	Annual Review: Checked Standards referenced Page 3 - Changed Revision table layout Page 8 - Added section 2.03 revision per SME Page 14 - Added section 3.06 revision per SME Page 20 - Updated section 3.14 TVA notification plan Page 27 - Added TVA requirements to Appendix A

# TABLE OF CONTENTS

## FACILITY CONNECTION REQUIREMENTS

### 1.0 INTRODUCTION

1.01	General Purpose	5
1.02	Technical Review Procedures	6
1.03	Technical Contact	6

### 2.0 INTERCONNECTION STUDIES

2.01	Initiating the Interconnection Process	7
2.02	System Impact Study	7
2.03	Facilities Study	8
2.04	Determination of New System Impact	9
2.05	Internal Processes for Development of Alternative Solutions	9
2.06	Coordination of Studies/ Sharing Information	9

### 3.0 TECHNICAL SPECIFICATIONS

3.01	MLGW Planning Criteria	10
3.02	Voltage Level & MW/MVAR Capacity at Point of Connection	11
3.03	Breaker Duty & Surge Protection	12
3.04	System Protection & Coordination	12
3.05	Metering & Telecommunications	13
3.06	DC System	14
3.07	Grounding & Safety Issues	14
3.08	Insulation & Insulation Coordination	16
3.09	Voltage, Reactive Power & Power Factor Requirements	17
3.10	Power Quality	18
3.11	Physical Access to Facilities	18
3.12	Equipment Ratings	19
3.13	Synchronization of Facilities	20
3.14	Coordination of Facility Maintenance	20
3.15	Abnormal Frequency & Voltage Operation	21
3.16	Inspection Requirements of New or Modified Facilities	21
3.17	Communications & Procedures During Normal & Emergency Conditions	22
3.18	MLGW Transmission Operator Contact Information	22

### 4.0 TRANSMISSION CONNECTION

4.01	General	23
------	---------	----

### 5.0 END-USER CONNECTION

5.01	Load Guidelines	24
5.02	Stability Studies	24

### 6.0 GENERATION CONNECTION

6.01	General	25
6.02	SCADA Requirements	25
6.03	Operating Voltage Requirements	25

### 7.0 MAKING AN OFFICIAL REQUEST

7.01	Instructions	26
------	--------------	----

### APPENDIX A : SYSTEM IMPACT STUDY REQUEST

27

### APPENDIX B : FACILITIES STUDY REQUEST FORM

32

# 1.0 INTRODUCTION

---

## FACILITY CONNECTION REQUIREMENTS

---

### *1.01 GENERAL PURPOSE*

This document pertains to equipment and facilities that operate at or above 100kV. Minimum requirements are defined for connecting transmission, end-user (load serving), or generation facilities to the Memphis Light, Gas and Water Division (MLGW) transmission system or to adjacent transmission systems when such interconnections have a material impact on the MLGW system. The requirements established in this document are intended to assure that facilities connected to the transmission system do not reduce the reliability or the operating flexibility of the Bulk Electric System (BES) and to assure that public safety is maintained.

It is recognized that while this document provides guidance on the technical issues that must be considered, it should not be considered an all-encompassing set of requirements or as a design specification manual. Specific projects must be reviewed on an individual basis, and final approval of any connection is at the discretion of MLGW.

Further, this document only addresses the technical requirements of connecting facilities to the MLGW system or to adjacent transmission systems when such interconnections have a material impact on the MLGW system. There is no attempt to address legal matters or liability issues related to connection and/or operation of said facilities.

Prospective Customers should also be aware that Tennessee Valley Authority (TVA), which is physically and contractually the electrical supplier to MLGW's system, will require project specifications in order to study the project's potential impacts on the TVA system. MLGW and TVA may communicate during the course of their independent studies, but it is the responsibility of the Customer to provide all necessary data to each organization.

Furthermore, any facility that operates at or above 100kV is subject to NERC (North American Electric Reliability Corporation) oversight, pursuant to the Federal Power Act 215. Prospective Customers should be aware of registration and compliance requirements. For further information, please contact MLGW's Utility Compliance Manager, at 901-322-5771. Potential customers may also find useful guidance on SERC Reliability Corporation's website ([www.serc1.org](http://www.serc1.org)). It is the Prospective Customer's responsibility to ascertain how regulatory compliance will be achieved, if applicable.

# 1.0 INTRODUCTION

---

## FACILITY CONNECTION REQUIREMENTS

---

### *1.02 TECHNICAL REVIEW PROCEDURES*

MLGW has a procedure in place to maintain and update its Facilities Connection Requirements document. This document will be reviewed annually, and changes will be made as needed.

The requirements set forth in this document apply to MLGW as well as to other entities who wish to interconnect generation, transmission, or end-user facilities to the MLGW-owned transmission system. Pursuant to NERC Reliability Standards pertaining to the BES at the time of this publication, these requirements apply to facilities that are connected to the transmission system at voltages 100 kV and above. If NERC issues changes to criteria in the future, such as lowering the voltage threshold of applicability, MLGW will adhere to the latest regulations regardless of specifications within this document. Revisions of this document related to changes in NERC Reliability Standards will be issued as needed.

### *1.03 TECHNICAL CONTACT*

Upon receipt of request for documentation on these interconnection requirements from NERC, SERC, or other authorized agency, MLGW will respond within five (5) business days. Email is the preferred form of response communication. All documentation requests should be sent to the Bulk Transmission Planner at [TransmissionPlanner@mlgw.org](mailto:TransmissionPlanner@mlgw.org)

MLGW's Transmission Planning department retains Facilities Connection Requirements documentation requests from users of the transmission system, SERC, and NERC. The list of received requests is available for review by regulatory agencies.

## 2.0 INTERCONNECTION STUDIES

### FACILITY CONNECTION REQUIREMENTS

#### *2.01 INITIATING THE INTERCONNECTION PROCESS*

For purposes of this document, the entity requesting interconnection service is referred to as “Customer”.

To initiate an official request for interconnection to the MLGW transmission system, the Customer shall complete and submit the System Impact Study Request Form, found in Appendix A of this document. Using the data submitted on the form, MLGW’s Transmission Planning department will perform studies on the proposed interconnection to evaluate the impact.

#### *2.02 SYSTEM IMPACT STUDY*

##### *Process*

Prior to beginning any study, MLGW must receive an official request for interconnection from the Customer. A System Impact Study Request Form can be found in Appendix A of this document. The submitted form must contain complete and accurate information and be accompanied by the escrow payment described below.

Upon receipt of the System Impact Study Request Form and the required escrow payment, MLGW will conduct a System Impact Study (SIS), at the expense of the Customer, as needed to determine system impact, reliability, and capability of the transmission system with the addition of the proposed interconnection.

##### *Costs*

By submittal of a System Impact Study Request Form, the Customer accepts responsibility for all costs associated with making improvements identified by the SIS, if the project moves forward.

The Customer is responsible for the costs associated with MLGW performing studies to determine the feasibility and impact of a proposed interconnection and requirements for connecting to the MLGW transmission system or to adjacent transmission systems. **A \$50,000 deposit is required before a System Impact Study will commence.** The deposit will go into an escrow account, and time spent on the study will be billed against the account. At the end of the study, remaining money in the account will be returned to the Customer, or credited towards the costs of system improvements necessitated by the proposed interconnection.

For Customer connections of End-User load only (no generation), the fees for the first study may be waived. Additional studies may incur cost. The cost for system upgrades will be the responsibility of the End-User Customer.

##### *Scope*

MLGW defines a System Impact Study as an assessment by the transmission provider of (i) adequacy of the transmission system to accommodate a request for transmission service and (ii) any additional cost to be incurred in order to provide transmission service.

The connection of the facility to the transmission system may result in the need for modifications at the location of the connection point as well as at other locations throughout the system due to changes in power flow, changes in available short circuit current, or impacts on system stability. These studies must be performed to determine the feasibility and impact of proposed interconnections to the MLGW transmission system or to adjacent transmission systems.

## 2.0 INTERCONNECTION STUDIES

### FACILITY CONNECTION REQUIREMENTS

The System Impact Study will consist of a short circuit analysis and a power flow analysis. Stability analysis will be performed if generation is involved in the proposed interconnection. The SIS will state the assumptions upon which it is based, state the results of the analyses, and provide the requirements or potential impediments to providing the requested interconnection service, including a preliminary indication of anticipated costs and project time duration that would be necessary to correct any problems identified and implement the interconnection. The SIS will provide a list of new or modified facilities that are required as a result of the System Impact Study Request, a non-binding good faith estimate of cost responsibility, and a non-binding good faith estimate of time required to construct the facilities. The SIS will also include evaluation of alternatives to the proposed interconnection.

#### *2.03 FACILITIES STUDY*

##### *Process*

If the Customer agrees to move forward with the interconnection process, a Facilities Study (FS) will be performed, at the expense of the Customer.

A Facilities Study Request Form can be found in Appendix B of this document. The submitted form must contain complete and accurate information and be accompanied by an escrow payment described below. Upon receipt of the Facilities Study Request Form and the required escrow payment, MLGW will conduct a Facilities Study (FS), at the expense of the Customer.

##### *Costs*

**A \$100,000 deposit is required before a Facilities Study will commence.** The deposit will go into an escrow account, and time spent on the study will be billed against the account. At the end of the study, any remaining money in the account will be returned to the Customer, or credited towards the costs of any system improvements necessitated by the proposed interconnection.

For Customer connections of End-User load only (no generation), the study fees may be waived for the first study. Additional studies may incur cost. The cost for system upgrades will be the responsibility of the End-User Customer.

##### *Scope*

A Facilities Study shall specify and estimate the cost of the equipment, engineering, procurement, and construction work needed to implement the conclusions of the SIS to physically and electrically connect the Interconnection Facility to the transmission system. The FS shall also estimate the time required for MLGW to complete the construction and installation of new facilities. It should be noted that if MLGW construction resources are not available due to existing workload then the Customer shall be responsible for the engineering, procurement, and construction activities. In that event, MLGW will review and approve the designs as well as inspect, test & check all facilities that MLGW will ultimately own and maintain. MLGW shall participate in Customer's Scoping Meetings and assign an MLGW Project Manager if necessary. If a proposed interconnection proceeds to the Facilities Study stage, MLGW will contribute in coordination of construction projects as needed.



## 2.0 INTERCONNECTION STUDIES

### FACILITY CONNECTION REQUIREMENTS

#### 2.04 DETERMINATION OF NEW SYSTEM IMPACT [FAC-001 R3.1]

A new impact is defined in Table 1.

1	A loading increase $\geq 5\%$ on transmission lines and/or transformers	AND	Loading on transmission lines and/or transformers $\geq 100\%$	For TPL-001-4 Table 1 Scenarios
2	A total fault current increase $\geq 5\%$	AND	Any breaker that is susceptible to total fault currents $\geq 95\%$ of rating	
3	Bus voltage change $\geq 5\%$	AND	Bus voltage $\leq 0.95$ nominal	For TPL-001-4 Table 1 Scenarios
4	A loading increase $\geq 20\%$ on transmission lines and/or transformers	AND	Loading on transmission lines and/or transformers $\geq 85\%$	For TPL-001-4 Table 1 Scenarios**
5	Any new transient stability issues			
6	Any new negative impacts on existing stability issues			

**Table 1**

\*\*The assessment of this impact will be subject to MLGW discretion.

#### 2.05 INTERNAL PROCESSES FOR DEVELOPMENT OF ALTERNATIVE SOLUTIONS

If a System Impact Study determines that the proposed interconnection violates MLGW Planning Criteria, increases loadings over acceptable thresholds, or exceeds breaker ratings, feasible alternatives will be determined and studied. Any alternatives that yield acceptable results in the follow-up System Impact Study will be discussed with the Customer.

#### 2.06 COORDINATION OF STUDIES/SHARING INFORMATION

MLGW will notify appropriate parties affected by the new or modified facilities that will be interconnected to the MLGW system. This notification will occur when the Customer agrees to proceed with construction of the interconnection facilities and prior to the energization or commercial operation date of the planned facilities. If MLGW determines that there is, or could be, an impact to a neighboring system, MLGW will notify the neighboring utility and invite them to participate in the study process. MLGW and neighboring utilities may communicate during the course of their independent studies, but it is the responsibility of the Customer to provide all necessary data. In cases in which an MLGW Customer is making modifications to new or existing facilities or MLGW becomes aware of a Customer's modifications to new or existing facilities, MLGW will notify any potentially impacted neighboring utilities as soon as feasible.

## 3.0 TECHNICAL SPECIFICATIONS

### FACILITY CONNECTION REQUIREMENTS

The requirements in Section 3 apply to all three interconnection types: transmission, end-user, and generation.

#### 3.01 MLGW PLANNING CRITERIA

In addition to the NERC Reliability Standards for transmission planning (TPL standards) and the SERC supplements, the following criteria are used by MLGW in planning the transmission system and also apply to all proposed interconnections. These criteria apply to conditions of firm power transfer between MLGW and TVA and to MLGW load forecasts that are based on “normal” weather and projected system conditions.

- ◆ TVA will continue to be the sole supplier of electricity to MLGW, per the current contract.
- ◆ MLGW has two transmission level voltages: 115kV and 161kV.
- ◆ Expansion of the 115kV system will be extremely limited.
- ◆ Distribution substations will be loop-fed with at least two transmission line sources. No T-tap substations will be permitted. See **Figure 1** for the minimum requirement of customer interconnection. For redundancy, the customer can request to have two meter points.
- ◆ Power-flow calculations will assume summer peak load at 101°F.
- ◆ The transmission system will be planned to meet the performance requirements of NERC Reliability Standards with (i) all transmission facilities in service or (ii) with one transmission circuit, tower, transformer, or generator out of service. Under these conditions, the maximum continuous rating of any remaining transmission facility should not be exceeded.
- ◆ Transmission power flow studies shall be performed according to NERC reliability requirements. MLGW applies contingency guidelines as specified in NERC standard TPL-001-4 Table 1 and the extent to which scenarios are applied are up to MLGW’s discretion.

**Figure 1**  
*A ring bus at the tap point and a Customer-owned breaker at the generating facility or substation shall be used to interconnect to the transmission system. Each new breaker shall have disconnect switches. With this arrangement, the loss of generation or the loss of Customer equipment does not interrupt flow on the MLGW transmission system. Furthermore, loss of a single transmission line does not result in loss of generation or electrical service to the Customer.*  
**[Figure is not to scale.]**

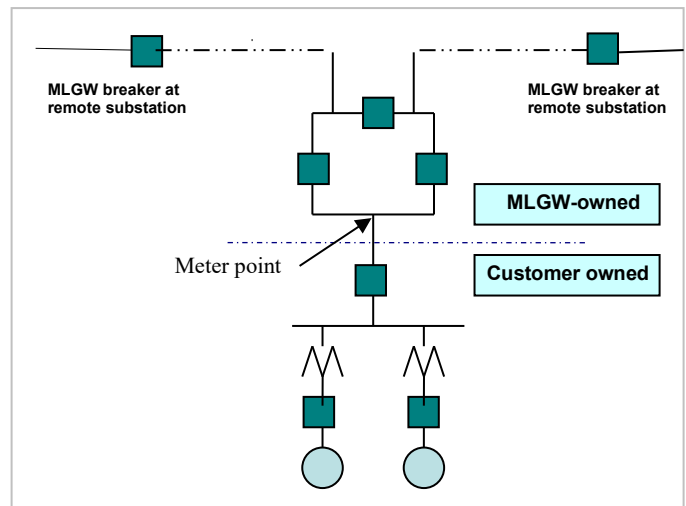

## 3.0 TECHNICAL SPECIFICATIONS

### FACILITY CONNECTION REQUIREMENTS

#### *3.02 VOLTAGE LEVEL & MW/MVAR CAPACITY AT POINT OF CONNECTION*

**MLGW Transmission System Voltages:** Nominal voltages of the MLGW transmission system are 115kV and 161kV.

**Interconnection Supply Voltage:** The interconnecting facility supplied from the transmission system, under system normal and single contingency conditions, will generally have voltages that range from 95% and 105% of nominal. In order to minimize possible adverse impacts to the operation of the Facility as a result of the BES operating under extreme voltage conditions, the Facility shall be designed to operate within the aforementioned range.

**Interconnection Capacity for Load:** The load connected to the transmission system cannot exceed the MW and MVAR capacity or demand levels requested and studied in the System Impact Study. If these levels need to be exceeded, another System Impact Study and Facilities Study may need to be performed. The Customer shall communicate these changes to MLGW prior to implementation.

**Interconnection Capacity for Generators:** The interconnecting generator facility cannot exceed the MVA level requested and studied in the System Impact Study. If the Customer wishes to exceed the studied MVA level, another System Impact Study and Facilities Study may need to be performed. The Customer shall communicate these changes to MLGW prior to implementation. Per Section 2.03, the Customer is responsible for all study costs and required system upgrades.

**Interconnection Capacity for Reactive Power Regulation:** All transmission interconnected equipment shall have the tap ranges and self-regulation necessary to accommodate the MLGW transmission system's reactive power flow requirements.

**Dynamic Stability and Power System Stabilizers:** MLGW requires that power system stabilizers be utilized for the conditions identified in SERC's document "[SERC Power System Stabilizer Guideline](#)".

**Interconnection Operating Frequency:** System nominal frequency is 60 Hz.

## 3.0 TECHNICAL SPECIFICATIONS

### FACILITY CONNECTION REQUIREMENTS

#### 3.03 SHORT-CIRCUIT CURRENT WITHSTAND & SURGE PROTECTION

All current-carrying equipment shall have short-circuit current withstand rating capable of withstanding thermal and mechanical loads from short-circuit currents equal to or greater than the short-circuit currents determined by analysis of MLGW and the Customer. Appropriate margins for future increase of short-circuit currents should be included in the determination of the short-circuit current withstand ratings.

In particular, the short-circuit current interrupting ratings and related capabilities of power circuit breakers shall be determined based on anticipated short-circuit currents determined from studies by MLGW. The Customer shall coordinate all ratings of power circuit breakers with MLGW.

As a minimum, the ratings, related required capabilities, and application of all equipment shall be in accordance with the latest editions of appropriate ANSI/IEEE standards.

- The Customer is responsible for the short circuit capabilities of their own current-carrying elements.
- The Customer is responsible for the ratings of their own interrupting devices.
- The Customer is responsible for the coordination of their relays and devices with the MLGW transmission system.
- Each Party shall supply the other all existing and planned future fault current level information upon request.
- The Customer is responsible for notifying MLGW of any changes in their facilities that may cause an increase in fault currents (Generator and Transmission Customers).
- The Customer is responsible for the cost to upgrade existing facilities due to increased fault currents, as outlined in Section 2.04.

Selected equipment shall be provided with surge protection in accordance with the latest edition of IEEE Std. C62.22. Equipment shall be protected from direct lightning stroke in accordance with the latest edition of IEEE Std. 998. Facilities and equipment are subject to MLGW review and approval.

#### 3.04 SYSTEM PROTECTION & COORDINATION

The Customer is responsible for purchasing and providing a protection system that will protect its equipment against disturbances on MLGW's system, minimize the effects of disturbances from its facilities on MLGW's equipment and transmission system, and provide for public safety. The protection system shall be designed to minimize equipment outage time, the system outage area, and system voltage disturbances. The Customer shall provide space in an MLGW-approved temperature-controlled control house for all necessary MLGW protection equipment. This may be in a separate house or in a partitioned and secured area of a shared house.

Primary and backup relaying is required. Minimum requirements are as follows:

- The protection system must be compatible with MLGW's applicable protection system.
- The Customer shall coordinate with MLGW and receive approval for the protection relay design and settings.
- Relays used in the protection system shall meet IEEE C37.90-2005 and IEEE C37.90.1-2012.

The method of transmission line protection communication shall be determined by MLGW.

## 3.0 TECHNICAL SPECIFICATIONS

### FACILITY CONNECTION REQUIREMENTS

#### 3.05 METERING AND TELECOMMUNICATIONS

MLGW shall specify, own, and maintain all meters and metering equipment (including RTU's) used to measure the delivery and receipt of energy for payment purposes. Meters in service are tested by MLGW annually or as requested by any lawfully constituted authority having jurisdiction over meter accuracy.

A voice telephone extension for the purpose of accessing MLGW's dial-up metering equipment and for communicating with MLGW's System Operation Center shall be provided by the Customer at its expense.

Typical generator and load metering data requirements include, but are not limited to, the following:

- kW
- kWhr
- kVAR, leading and lagging
- kVAR-hour
- Voltage

#### *Instrument Transformers*

Instrument transformers include wound type voltage and current transformers and coupling capacitor voltage transformers. All metering instrument transformers installed must be designed, manufactured, and applied in accordance with IEEE Standard C57.13-2016. The Customer must purchase metering equipment capable of providing the minimum data specified by MLGW. The burdens placed on instrument transformers shall be within the limits required to ensure the accuracy required by the application. Metering accuracy will be specified by MLGW.

Test reports and certification records shall be maintained and made available to MLGW upon request.

#### *SCADA (Supervisory Control & Data Acquisition)*

An RTU (remote terminal unit) will be required for gathering Customer load and equipment status information to be telemetered back to MLGW. The Customer will reimburse MLGW for the required RTU or can purchase and provide an RTU that meets MLGW specifications. MLGW will own and maintain the SCADA devices. MLGW will specify the required protocol and method of communication (*e.g.* fiber optic cable, phone line).

Instantaneous bi-directional analog real power and reactive power flow information must be telemetered directly to the location(s) specified by MLGW.

Typical data requirements include, but are not limited to, the following:

- Status of interrupting devices
- MW flow
- MVAR flow
- Current
- Power factor
- Voltage

## 3.0 TECHNICAL SPECIFICATIONS

### FACILITY CONNECTION REQUIREMENTS

#### 3.06 DC SYSTEM

A complete, separate 125 VDC system for MLGW's equipment and protection system shall be provided by the Customer. The DC system shall consist of an appropriately sized nickel-cadmium (NiCd) station battery (125 volts DC nominal), a battery charger, a DC distribution panelboard, and any required isolating safety switches.

The battery shall consist of individual NiCd battery cells and shall be sized, installed, and maintained in accordance with the latest edition of IEEE Std. 1115 and IEEE Std. 1106 to provide reliable battery operation. The battery and rack shall be seismically anchored, and the rack shall conform to IEEE 693 High requirements. The battery rack system shall include a properly sized spill containment system.

The battery shall be maintained fully charged state by being continuously connected to a suitably sized battery charger that derives its energy from a station service as described in Section 3.12. The battery charger shall be sized to charge a fully discharged battery in 12 hours, in addition to carrying the continuous DC load. The battery charger shall have a "battery eliminator option" which allows for serving the DC load even if the battery is removed.

A DC distribution panelboard provided with molded case circuit breakers shall provide coordinated overcurrent protection from the battery to each individual DC load. Overcurrent protection of battery conductors shall be provided. The panelboard and all molded case circuit breakers shall be rated for DC application. There shall be no cross connection between DC circuits.

A safety switch rated for 125 VDC operation shall be installed to provide disconnecting means of ungrounded conductors from the battery if the DC panelboard main breaker is not within sight of the battery.

The DC system facilities and equipment are subject to MLGW review and approval.

#### 3.07 GROUNDING AND SAFETY ISSUES

##### **System Grounding**

A bus is considered to be "effectively grounded" when the following relationships are true:

- $X_o/X_1 \leq 3$
- $R_o/X_1 \leq 1$

This relationship assumes  $R_1/X_1 = 0$ , which is a worst case condition. If one or both of these relationships are not true, the effective grounding should be checked more precisely by referring to the curves found in IEEE Standard C62.92.1-2016 Figure A.2. The proper curve to use should be based on the actual  $R_1/X_1$  ratio. Any set of ratios lying below the appropriate curve marked 80% will provide effective grounding for 80% lightning arresters used on MLGW's system.

The substation grounding system in general shall provide for personnel safety and enable coordinated system protection.

The substation grounding design shall meet IEEE Std. 80, IEEE Std. 81, IEEE Std. 142, and ANSI C2. The calculations should include allowances for system load growth as well as load growth at this facility.

## 3.0 TECHNICAL SPECIFICATIONS

### FACILITY CONNECTION REQUIREMENTS

The measured soil resistivity values (two-layer model) for the substation site, calculated and measured resistance of the substation to remote earth, available fault current and maximum substation ground grid current, calculated ground potential rise to remote earth, and maximum allowable and calculated step and touch potentials shall be noted on the grounding plan drawing(s). The ground grid shall extend a minimum of 5 feet outside the fenced area.

Grounded systems shall adhere to IEEE 80 and NESC which include requirements for:

- Safety criteria: Calculated step and touch potentials shall be less than the maximum allowable voltages calculated in accordance with IEEE 80.
- Design output: Maximum and allowable touch and step potentials, ground potential rise, soil model, maximum fault and grid current, and calculated grid resistance.
- Connections: Only exothermic welds below grade and bolted connections above grade.

When the interconnecting facility is within the MLGW substation fence, the interconnecting facility will be incorporated into the design and construction of the MLGW ground grid. When the facility is outside of the MLGW substation fence, the interconnecting facility shall have its own independent ground grid. When the MLGW substation and the interconnecting facility are adjacent to each other, the grids shall be connected together. The specifics for coordination of the interties between ground grids are discussed at pre-design meetings. The ground grid to be interconnected with the MLGW ground grid shall be of compatible design and shall consist of 500 kcmil copper cable.

The required structure ground resistance on all new transmission construction shall be 10 ohms or less.

#### *Safety*

When making an interconnection to MLGW's system, the Customer shall comply with applicable safety laws, including provisions of applicable Federal, State, and local safety, health, or industrial regulations or codes.

MLGW shall make final determination as to whether the MLGW facilities are properly protected before an interconnection is energized. The Customer is responsible for proper protection of their own equipment and for correcting such problems before the facilities are energized or interconnected operation begins.



## 3.0 TECHNICAL SPECIFICATIONS

### FACILITY CONNECTION REQUIREMENTS

#### 3.08 INSULATION & INSULATION COORDINATION

Insulation coordination is the selection of insulation strength. Insulation coordination must be done properly to ensure electrical system reliability and personnel safety. Basic Surge Levels (BSLs), surge arrester ratings, conductor spacing and gap application, substation and transmission line insulation strength, protection, and shielding shall be documented and submitted for evaluation as part of the interconnection plan.

Substations and transmission lines should be shielded from direct lightning strokes. Surge arresters shall be applied at major components and systems.

Interconnection facilities to be constructed in areas with contamination shall be properly designed to meet or exceed the performance of facilities not in a contamination area with regard to contamination caused outages.

Lines, buses, and other equipment shall be insulated for the respective voltage level, as shown in Table 2 below:

Nominal kV	Insulation BIL kV
161	750
115	550
23Y	150
12.47Y	110

**Table 2**

Insulation for power transformers shall be as listed in Table 3 below:

Nominal kV	Line Terminals:		Neutral Terminals:	
	Insulation BIL kV	Bushing BIL kV	Insulation BIL kV	Bushing BIL kV
161	650	750	450	550
115	550	550	350	350
23Y	150	150	150	150
12.47Y	110	150	110	150

**Table 3**



## 3.0 TECHNICAL SPECIFICATIONS

### FACILITY CONNECTION REQUIREMENTS

#### *3.09 VOLTAGE, REACTIVE POWER & POWER FACTOR REQUIREMENTS*

Unless otherwise agreed, the Customer is required to maintain voltage levels within acceptable ranges, approximately 2% to 5% above nominal, pursuant to Good Utility Practices. Transmission interconnected equipment shall have the tap ranges and self-regulation necessary to operate within the MLGW transmission system's voltage range, referenced in Section 3.02.

It is the responsibility of the Customer to incorporate appropriate voltage regulating equipment in their facility if the facility's supply voltage requirements are more restrictive than the MLGW transmission system's voltage range.

The Customer is obligated to provide for the facility's reactive power needs as well as be capable of absorbing reactive power. Unless otherwise agreed, the Customer is required to maintain power factor levels within the acceptable ranges shown in Table 4, pursuant to Good Utility Practices. All reactive resources must be capable of operating within the voltage limits stated in Section 3.02. Switched reactive resources shall not introduce voltage transients on the transmission system.

<b>ACCEPTABLE CUSTOMER POWER FACTOR RANGES</b>	
<b>On-Peak Hours</b> (June 1 – October 1, noon – 8:00 pm)	0.97 (lagging) to 0.98 (leading)
<b>Off-Peak Hours</b> (all other hours)	0.95 (lagging) to 1.00 (unity)

**Table 4**

#### *Motor Start Studies*

For both existing and proposed facilities, any newly proposed motor that is rated at or above 200 HP requires a system motor start study. The purpose of the study is to determine if the starting of the motor causes a detrimental impact on system voltage. The MLGW Bulk Planning Engineer will perform the study and will work with the Customer on possible solutions to mitigate identified impacts. The study shall be performed before the motor is connected, and all impacts shall be mitigated by mutually-agreed-upon methods prior to energization of the motor.

## 3.0 TECHNICAL SPECIFICATIONS

### FACILITY CONNECTION REQUIREMENTS

#### 3.10 POWER QUALITY

Any connection of a transmission facility, end user load, or generator to MLGW's electric transmission system should not compromise or degrade the power quality of MLGW or its existing customers. The installation of a permanent digital fault recorder or other power quality monitoring equipment may be deemed necessary by MLGW. Installation would be at the point of common coupling (PCC) and would ensure that all applicable federal, state, and local power quality standards are met and maintained, and that power quality events are captured and analyzed.

Power quality events shall be governed by the referenced standard and will include but may not be limited to:

- Voltage Imbalance (ANSI/IEEE C84.1)
- Voltage Flicker (IEEE P1453)
- Voltage Fluctuation (IEEE P1250)
- Harmonic Distortion (IEEE 519)
- Transient Overvoltage (IEEE C62.41)
- Temporary Overvoltage (ANSI/IEEE C84.1 and IEEE C62.41)
- Temporary Undervoltage (ANSI/IEEE C84.1)
- Operating Frequency (ANSI/IEEE C84.1 Appendix)
- Power Factor Range (see Section 3.9 on page 14 for acceptable limits)
- Interruption / Outage frequency as may be required by regulatory standards (ITI curve, formerly CBEMA curve)
- Faults due to short circuit or open circuit conditions (MLGW's relay coordination protection scheme)

Studies may identify additional equipment necessary to meet these power quality standards.

#### 3.11 PHYSICAL ACCESS TO FACILITIES

MLGW shall have unlimited and unrestricted physical access to MLGW facilities. Physical access to shared property shall be unencumbered. Any fences that enclose MLGW property shall have an MLGW lock to allow access by MLGW personnel. A separate entry point for MLGW personnel is preferred. There shall be no required check-in at a security station or other impediments to access.

## 3.0 TECHNICAL SPECIFICATIONS

---

### FACILITY CONNECTION REQUIREMENTS

---

#### *3.12 EQUIPMENT RATINGS*

All current-carrying equipment shall be designed to carry the maximum loads that are predicted and used in load flow analysis. Facility loading exceeding “nameplate” design capabilities is only acceptable when allowed by manufacturer’s design documentation or standard industry practices. MLGW shall have the express right to review Customer design and specifications to verify that equipment ratings are consistent with MLGW criteria. Equipment ratings must meet requirements identified in system studies, latest industry standards (ANSI, NEMA, IEEE), and MLGW equipment specifications. Equipment ratings shall be established and communicated in accordance with the current approved versions of NERC Reliability Standards FAC-008.

#### *Surge Arresters*

See Section 3.03 for surge arrester information.

#### *Breakers*

See Section 3.03 for breaker rating information.

#### *Instrument Transformers*

See Section 3.05 for instrument transformer requirements.

#### *Station Service*

Station service power shall be provided to operate MLGW’s substation equipment, various pieces of test and maintenance equipment, and station lighting. A distribution panelboard shall be included that provides coordinated overcurrent protection from the secondary of the station service transformers to each individual AC load. There shall be a means of establishing a visible air gap between the distribution panelboard and the source.

## 3.0 TECHNICAL SPECIFICATIONS

### FACILITY CONNECTION REQUIREMENTS

#### 3.13 SYNCHRONIZATION OF FACILITIES

Synchronization of an interconnected generator shall be accomplished by Customer-provided equipment suitable to measure both the phase angle across the breaker and the voltage on each side of the breaker. Transmission breakers will be closed to connect two energized lines only after the phase angle across the breaker is verified. This will be accomplished by one of two methods.

In the first method, manual closing utilizes a sync permissive switch. The switch must be turned on to allow breaker closing. Turning on the switch energizes a synchroscope, which shows the phase angle between the lines to be tied together. This method requires a Transmission Operator to determine that the angle is within limits. The Customer shall be responsible for the synchronization of generation with the transmission system, and communicating with MLGW's System Operations personnel as needed.

If a transmission outage occurs that does not separate the generation from the transmission system, then a second method of synchronization is used that will allow automatic reclosing relays to re-connect. The control scheme initiates a close only after a synchro-verifier relay determines that the angle and voltage are within preset limits.

#### 3.14 COORDINATION OF FACILITY MAINTENANCE

In order to appropriately maintain facilities, MLGW shall test and maintain equipment on an established schedule. This includes taking facilities out of service for de-energized testing. Courtesy notification may be made to the Customer, but the Customer shall not prevent scheduled testing from taking place.

In order to minimize the risk to the Bulk Electric System, the Customer shall coordinate work scheduling, foreseeable planned outages, and equipment maintenance and testing with MLGW to ensure that proper maintenance is performed on all equipment. In turn, MLGW must notify TVA of the planned work per the MLGW/TVA Work Scheduling and Notification Agreement. The following are key requirements of the Agreement with which the Customer must comply in order for MLGW to be in compliance with current NERC regulations:

- A seven day notification of planned work is required when bypassing circuit breakers and removing lines from service.
- Bus differential protection systems shall stay in service at all times except during testing, maintenance and/or modification to its components.

The maintenance practices of the interconnected facility owner/operator on their transmission-connected equipment shall be performed at a level that ensures the reliability and continuity of service of the interconnected transmission system. Relevant maintenance records shall be maintained and shall be provided to MLGW upon request.

## 3.0 TECHNICAL SPECIFICATIONS

---

### FACILITY CONNECTION REQUIREMENTS

---

#### *3.15 ABNORMAL FREQUENCY AND VOLTAGE OPERATION*

When a Customer desires to interconnect a facility to the MLGW system, the protection scheme and settings must be submitted to MLGW for review. MLGW will review to ensure that proper and adequate coordination between MLGW and the Customer's protection schemes exists, in order to maintain system stability. MLGW will also ensure that the Customer's frequency protection meets MLGW requirements and the proper and adequate metering is in place to monitor abnormal voltage conditions.

It shall be the responsibility of the Customer to provide adequate protection or safeguards to prevent damage to MLGW caused by over/under frequency or over/under voltage originating in the interconnecting facility. Additionally, the Customer shall provide adequate protection and safeguards to protect the interconnected facility from inadvertent over/under frequency or over/under voltage conditions originating on the MLGW system. Steady-state voltages must be maintained within the limits as defined in Section 3.02 of this document.

#### *3.16 INSPECTION REQUIREMENTS OF NEW OR MODIFIED FACILITIES*

Prior to energizing a new or modified facility, MLGW personnel shall have the right to perform an inspection.

Each interconnecting party (MLGW and the Customer) shall have the right to observe the testing of any of the other's interconnecting facility or equipment that may reasonably be expected to affect the reliability of the observing party's facilities and equipment.

## 3.0 TECHNICAL SPECIFICATIONS

### FACILITY CONNECTION REQUIREMENTS

#### *3.17 COMMUNICATIONS & PROCEDURES DURING NORMAL & EMERGENCY CONDITIONS*

Operational communications between an interconnected facility and the MLGW Transmission Operator shall be active and be maintained under both normal and emergency conditions.

The Customer shall establish a contact person for communications with MLGW's Transmission Operations staff. This contact person shall have the authority and capability to operate the facilities per the instructions of MLGW. Any change in personnel shall be immediately communicated to MLGW's Transmission Operations staff. There shall be a provision for an adequate and reliable communication path(s) between MLGW and the Customer Interconnection Facility.

An Emergency Condition shall mean a condition or situation: (1) that in the judgment of the Party making the claim is imminently likely to endanger life or property; or (2) that, in the case of MLGW, is imminently likely to cause a material adverse effect on the security of or damage to MLGW's Transmission System, TVA's Interconnection Facilities, or the electric systems of others to which MLGW's Transmission System is directly connected; or (3) that, in the case of Interconnection Customer, is imminently likely to cause a material adverse effect on the security of or damage to the Interconnection Customer's Interconnection Facilities.

MLGW may, consistent with Good Utility Practices, take whatever action or inaction with regard to its Transmission System it deems necessary during an Emergency Condition in order to (1) preserve public health and safety; (2) preserve the reliability of the Transmission System; (3) limit or prevent damage; and (4) expedite restoration of service. This authority is granted to MLGW by NERC due to MLGW's registration as a Transmission Owner (TO) and a Transmission Operator (TOP). This includes deenergizing any facility that is or is expected to impact the reliability of the BES. MLGW is not required to seek permission nor will MLGW seek permission. MLGW's obligation is to protect the integrity of the system as a whole.

MLGW is obligated to comply with all Reliability Directives issued by TVA, which serves as MLGW's Reliability Coordinator (RC), unless such actions would violate safety, equipment, or regulatory or statutory requirements (per NERC Reliability Standard IRO-001).

#### *3.18 MLGW TRANSMISSION OPERATOR CONTACT INFORMATION*

The contact information for MLGW System Operations is shown in Table 5. In emergencies where phone lines are not available, MLGW will transmit information via local news agencies.

TITLE	PHONE NUMBER
Supervisor, Systems Operations	901.372.5662
Coordinator, Systems Operations	901.372.5668
System Operator—Dispatcher's Desk	901.213.1297

**Table 5**

## 4.0 TRANSMISSION CONNECTION

---

### FACILITY CONNECTION REQUIREMENTS

---

#### *4.01 GENERAL*

Transmission interconnections are planned such that the transmission system will be adequate to withstand the most severe single contingency condition and maintain an acceptable level of reliability. The North American Electric Reliability Corporation (NERC) and the SERC Reliability Corporation have established planning criteria which must be met to assure reliable electric service to all areas of the United States. See Section 3.01 for MLGW's Transmission Planning Criteria and the required transmission connection arrangement.

## 5.0 END-USER CONNECTION

### FACILITY CONNECTION REQUIREMENTS

#### 5.01 LOAD GUIDELINES

Transmission facilities may be used for providing service to commercial, industrial, and cogeneration Customers when the use of distribution feeders is not practicable. See Section 3.01 for MLGW's Transmission Planning Criteria and the required transmission connection arrangement.

The feasibility of serving Customers directly from transmission requires a comprehensive study and coordination. Some factors to be considered prior to agreeing on a Customer connection are as follows:

- Economics of alternatives
- Customer parallel generation
- Transmission line length
- Customer transformer characteristics
- Customer switching
- Effect on protective relaying at remote terminals
- Problems of large through-power on looped lines
- Extent of Customer facilities

The following are typical preferred minimum load demands for connecting to existing transmission lines:

- 161 kV – 30 MVA
- 115 kV – 20 MVA

The load connected to the transmission system cannot exceed the MW and MVAR capacity or demand levels requested and studied in the System Impact Study. If these levels need to be exceeded, another System Impact Study and Facilities Study may need to be performed. The Customer shall communicate these changes to MLGW prior to implementation.

#### 5.02 STABILITY STUDIES

If an interconnected Customer has plans for internal generation, a stability study may be required. The Customer must supply a detailed description of the Customer's load characteristics, internal distribution system representation, generating equipment models and data, etc. The Customer will reimburse all expenses incurred by MLGW in performing such a study.



## 6.0 GENERATION CONNECTION

### FACILITY CONNECTION REQUIREMENTS

#### 6.01 GENERAL

It is critical to address issues specific to connecting generating facilities to MLGW's transmission system. In instances where the generation is standby only, appropriate lockouts and/or switches to prevent parallel operations are required.

System configurations vary depending upon the location and size of the generation. Due to short circuit contributions and the effects on protective relaying, the installation of a transmission substation is often required. See Section 3.01 for MLGW's Transmission Planning Criteria and the required transmission connection arrangement.

The interconnecting generator facility cannot exceed the MVA level requested and studied in the System Impact Study. If the Customer wishes to exceed the studied MVA level, another System Impact Study and Facilities Study may need to be performed. The Customer shall communicate these changes to MLGW prior to implementation. Per Section 2.03, the Customer is responsible for all study costs and required system upgrades.

#### 6.02 SCADA REQUIREMENTS

Prior to the operation of a generation facility, an RTU or equivalent data collection and communication device acceptable to both MLGW and the Customer shall be installed by MLGW at the Customer's expense. This equipment will gather accumulated and instantaneous data to be telemetered to a location determined by MLGW through use of a dedicated point to point data circuit(s). The communication protocol for this data circuit(s) shall be specified by MLGW. Instantaneous voltage data plus bi-directional analog real power and reactive power flow information must be telemetered directly to the location specified by MLGW. Refer to Section 3.05 of this document for more information.

#### 6.03 OPERATING VOLTAGE REQUIREMENTS

If the Point of Interconnection is at a nominal voltage of 161,000 volts, the normal operating voltage range for the Facility is expected to be approximately 164kV to 170kV, with 168kV being the expected optimal operating voltage.

If the Point of Interconnection is at a nominal voltage of 115,000 volts, the normal operating voltage range for the Facility is expected to be approximately 117kV to 120kV, with 118kV being the expected optimal operating voltage.

## 7.0 MAKING AN OFFICIAL REQUEST

---

### FACILITY CONNECTION REQUIREMENTS

---

#### *7.01 INSTRUCTIONS*

To initiate a System Impact Study and/or Facilities Study, the Customer must provide the requested information in its entirety on the following forms. MLGW will not proceed with an interconnection study or a project cost estimate until all data is received.

Interconnection study results are dependent on study data provided by the Customer. Notification of any changes to data must be provided as promptly as possible. Any change in the study data can impact the length of time required for the study and the study results.

The Request Form(s) should be emailed to [TransmissionPlanner@mlgw.org](mailto:TransmissionPlanner@mlgw.org) or mailed to:

**Memphis Light, Gas and Water Division**  
**Transmission and Operational Planning Engineering**  
*Attention: Transmission Planner*  
**2425 Covington Pike, OF-01/200**  
**Memphis, TN 38128**

Upon receipt of the request, the Customer will be contacted by the Transmission Planner within 10 business days to initiate communication and confirm receipt. The Request Form(s) should designate a subject matter expert who can adeptly answer questions about the proposed project and technical equipment specifications.

***APPENDIX A******System Impact Study Request Form***

Prospective Interconnection Customers must fully complete the following form. MLGW will not proceed with an interconnection study until all data is received. Please contact the Transmission Planner in Transmission and Operational Planning Engineering at 901.372.5626 with questions about the form. Before starting any study, modeling data per the TVA Modeling Requirements document will be requested. The document can be found on the TVA Oasis site or here:  
[www.oasis.oati.com/woa/docs/TVA/TVAdocs/TVA\\_Modeling\\_Requirements.pdf](http://www.oasis.oati.com/woa/docs/TVA/TVAdocs/TVA_Modeling_Requirements.pdf)

**1. Requestor of Interconnection Study**

Customer Name: \_\_\_\_\_

Address: \_\_\_\_\_

\_\_\_\_\_

Phone Number: \_\_\_\_\_

Application Submitted By: \_\_\_\_\_

Position: \_\_\_\_\_

Phone Number: \_\_\_\_\_

E-mail address: \_\_\_\_\_

Date: \_\_\_\_\_

**2. Description of Request**

a) Type of Request (check one)

\_\_\_\_\_ Transmission Connection

\_\_\_\_\_ Generation Connection

\_\_\_\_\_ End-User Connection

b) Capacity (MW): \_\_\_\_\_

**3. Details of Request**

a) Location of Interconnection \_\_\_\_\_

\_\_\_\_\_

\_\_\_\_\_

b) Single Line Diagram

Attach a single line diagram, dimensioned in miles, illustrating the proposed Customer switchyard and the distance of the proposed point of interconnection from the nearest substation.

c) Expected In Service Date (ISD): \_\_\_\_\_

d) Voltage level requested for interconnection (check one)

\_\_\_\_\_ 115kV

\_\_\_\_\_ 161kV

**4. Generator Specifications (if applicable)**

- a) Type of Generation (simple cycle, combined cycle, co-generation, etc)
- b) Generator Rating: \_\_\_\_\_ MW at \_\_\_\_\_ °F
- c) Expected Load Factor of Generation: \_\_\_\_\_
- d) Generator Base MVA: \_\_\_\_\_
- e) Generator Active Power Output (full load MVA): \_\_\_\_\_
- f) Generator Reactive Power Output (MVAR): \_\_\_\_\_
  - i. Maximum Reactive Power Output: \_\_\_\_\_
  - ii. Minimum Reactive Power Output: \_\_\_\_\_
- g) Generator Rated Terminal Power Factor:
  - i. Lagging: \_\_\_\_\_
  - ii. Leading: \_\_\_\_\_
- h) Generator Rated Terminal Voltage in kV: \_\_\_\_\_
- i) Provide all applicable Generator reactances in per unit on specified MVA base:
  - i.  $X_d$  (direct axis synchronous reactance) \_\_\_\_\_
  - ii.  $X_d'$  (direct axis synchronous transient reactance) \_\_\_\_\_
  - iii.  $X_d''$  (direct axis synchronous sub-transient reactance) \_\_\_\_\_
  - iv.  $X_q$  (quadrature axis synchronous reactance) \_\_\_\_\_
  - v.  $X_q'$  (quadrature axis synchronous transient reactance) \_\_\_\_\_
  - vi.  $X_q''$  (quadrature axis synchronous sub-transient reactance) \_\_\_\_\_
  - vii.  $X_l$  (leakage reactance) \_\_\_\_\_
- j) Positive sequence reactance in per unit: \_\_\_\_\_
- k) Negative sequence reactance in per unit: \_\_\_\_\_
- l) Zero sequence reactance in per unit: \_\_\_\_\_
- m) Neutral grounding resistor in ohms (if applicable): \_\_\_\_\_
- n) RPM: \_\_\_\_\_
- o) Frequency: \_\_\_\_\_
- p) Phase (check one):
  - a. Single phase \_\_\_\_\_
  - b. Three phase \_\_\_\_\_

**5. Circuit Breaker Data (if applicable)**

- a) Rated Voltage in kV: \_\_\_\_\_ (maximum line-to-line RMS at 60 Hz)
- b) Rated Amps: \_\_\_\_\_ (maximum continuous RMS at 60 Hz)
- c) Interrupting current rating: \_\_\_\_\_
- d) Rated interrupting time: \_\_\_\_\_
- e) BIL rating: \_\_\_\_\_
- f) Interrupting and insulating media: \_\_\_\_\_
- g) Tripping and closing control voltages: \_\_\_\_\_
- h) Relay accuracy class: \_\_\_\_\_
- i) Cycles required for interrupting: \_\_\_\_\_

**6. Generator Step-up Transformer Data (if applicable)**

**A. Two-winding step-up transformer**

- 1. Base MVA: \_\_\_\_\_
- 2. Full Load Ratings (OA/FA/FOA): \_\_\_\_\_
- 3. Sequence Impedances (R + jX) in per unit:
  - Positive: \_\_\_\_\_
  - Negative: \_\_\_\_\_
  - Zero: \_\_\_\_\_
- 4. Available Tap positions: \_\_\_\_\_
- 5. Rated Voltage in kV
  - High Side: \_\_\_\_\_
  - Low Side: \_\_\_\_\_
- 6. X/R ratio: \_\_\_\_\_
- 7. Neutral Grounding Resistor in Ohms (if applicable): \_\_\_\_\_
- 8. BIL Rating: \_\_\_\_\_
- 9. Impedance to Ground: \_\_\_\_\_
- 10. Load losses in watts: \_\_\_\_\_

**B. Three-winding step-up transformer****(provide connection and winding info on a one-line diagram)**

1. Provide the following:

- H-winding data
  - i. Full Load MVA Rating (OA, FA, FOA) \_\_\_\_\_
  - ii. Rated kV Base \_\_\_\_\_
  - iii. Grounding Data \_\_\_\_\_
  - iv. BIL Rating \_\_\_\_\_
- X-winding data
  - i. Full Load MVA Rating (OA, FA, FOA) \_\_\_\_\_
  - ii. Rated kV Base \_\_\_\_\_
  - iii. Grounding Data \_\_\_\_\_
  - iv. BIL Rating \_\_\_\_\_
- Y-winding data
  - i. Full Load MVA Rating (OA, FA, FOA) \_\_\_\_\_
  - ii. Rated kV Base \_\_\_\_\_
  - iii. Grounding Data \_\_\_\_\_
  - iv. BIL Rating \_\_\_\_\_

2. Sequence Impedances ( $R + jX$ ) in per unit:

H-X winding data for \_\_\_\_\_ base MVA:

- Positive: \_\_\_\_\_
- Negative: \_\_\_\_\_
- Zero: \_\_\_\_\_

Tap Positions: \_\_\_\_\_

H-Y winding data for \_\_\_\_\_ base MVA:

- Positive: \_\_\_\_\_
- Negative: \_\_\_\_\_
- Zero: \_\_\_\_\_

Tap Positions: \_\_\_\_\_

X-Y winding data for \_\_\_\_\_ base MVA:

- Positive: \_\_\_\_\_
- Negative: \_\_\_\_\_
- Zero: \_\_\_\_\_

Tap Positions: \_\_\_\_\_



***APPENDIX B***

***Facilities Study Request Form***

This form shall be fully completed. MLGW will not proceed with a Facilities Study until all data is received. Please contact the Transmission Planner in Transmission and Operational Planning Engineering at 901.372.5626 with questions about the form.

**1. Requestor of Facilities Study**

Customer Name: \_\_\_\_\_

Address: \_\_\_\_\_

\_\_\_\_\_

Phone Number: \_\_\_\_\_

Application Submitted By: \_\_\_\_\_

Position: \_\_\_\_\_

Phone Number: \_\_\_\_\_

E-mail address: \_\_\_\_\_

Date: \_\_\_\_\_

**2. Project Capacity in MW:** \_\_\_\_\_

**3. Location of Interconnection:** \_\_\_\_\_

\_\_\_\_\_

**4. Project Schedule (planned):**

Scoping Meeting Date (if known): \_\_\_\_\_

Construction Start Date: \_\_\_\_\_

Construction Complete Date: \_\_\_\_\_

Expected Energization Date: \_\_\_\_\_